

GATE NO'S:		G1
NO. REQD.	1	
DESCRIP.	DOUBLE GRILLE GATE CONSTRUCTED FROM 25 X 25 X 2.5MM SQUARE SECTION TUBING WITH 10MM SOLID M/S RODS AT APPROX. 120MM CENTRES. PROVIDE 4MMØ WEEP HOLES TO BOTTOM OF ALL TUBING.	
IRONM.	UNION PADLOCK CODE 3122-51 HEAVY DUTY PADLOCK WITH BRASS BODY S/S SHACKLE 5 PIN TUMBLER. SOLID 100MM BARREL BOLT TO TAKE PADLOCK.	
FINISH	PRE-PAINTED POWDER COATED SATIN BLACK ON TOP OF A UNIVERSAL RED OXIDE METAL PRIMER SOLVENT-BASED ANTI-CORROSIVE METAL PRIMER	
REMARKS	ALL DIMENSIONS TO BE CHECKED ON SITE PRIOR TO MANUFACTURE. PIN HINGES TO BE BOLTED TO FACE BRICK WALL.	

OPD GATE 1
SCALE 1-50

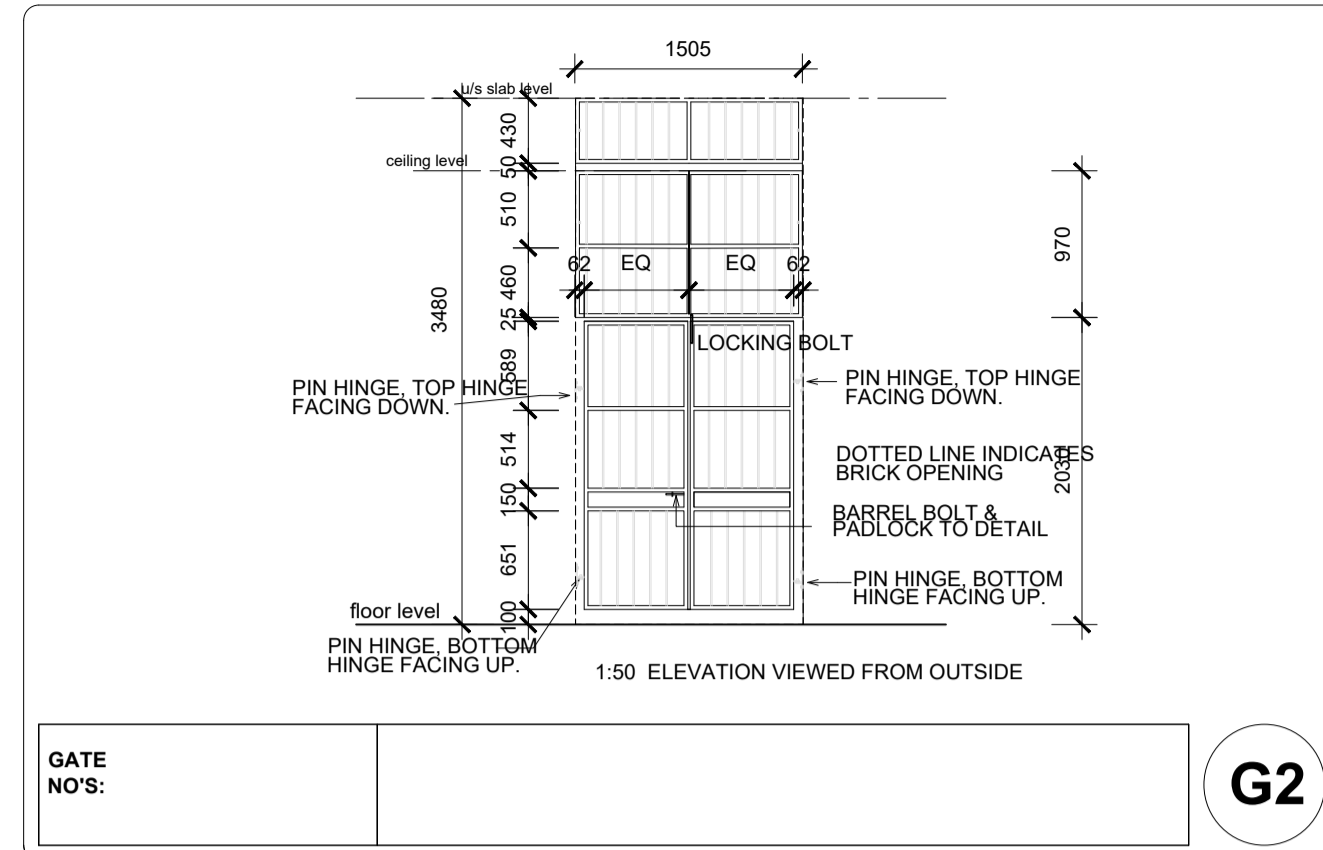

GATE NO'S:		G2
NO. REQD.	1	
DESCRIP.	DOUBLE GRILLE GATE CONSTRUCTED FROM 25 X 25 X 2.5MM SQUARE SECTION TUBING WITH 10MM SOLID M/S RODS AT APPROX. 120MM CENTRES. PROVIDE 4MMØ WEEP HOLES TO BOTTOM OF ALL TUBING.	
IRONM.	UNION PADLOCK CODE 3122-51 HEAVY DUTY PADLOCK WITH BRASS BODY S/S SHACKLE 5 PIN TUMBLER. SOLID 100MM BARREL BOLT TO TAKE PADLOCK.	
FINISH	PRE-PAINTED POWDER COATED SATIN BLACK ON TOP OF A UNIVERSAL RED OXIDE METAL PRIMER SOLVENT-BASED ANTI-CORROSIVE METAL PRIMER	
REMARKS	ALL DIMENSIONS TO BE CHECKED ON SITE PRIOR TO MANUFACTURE. PIN HINGES TO BE BOLTED TO FACE BRICK WALL.	

OPD GATE 2
SCALE 1-50

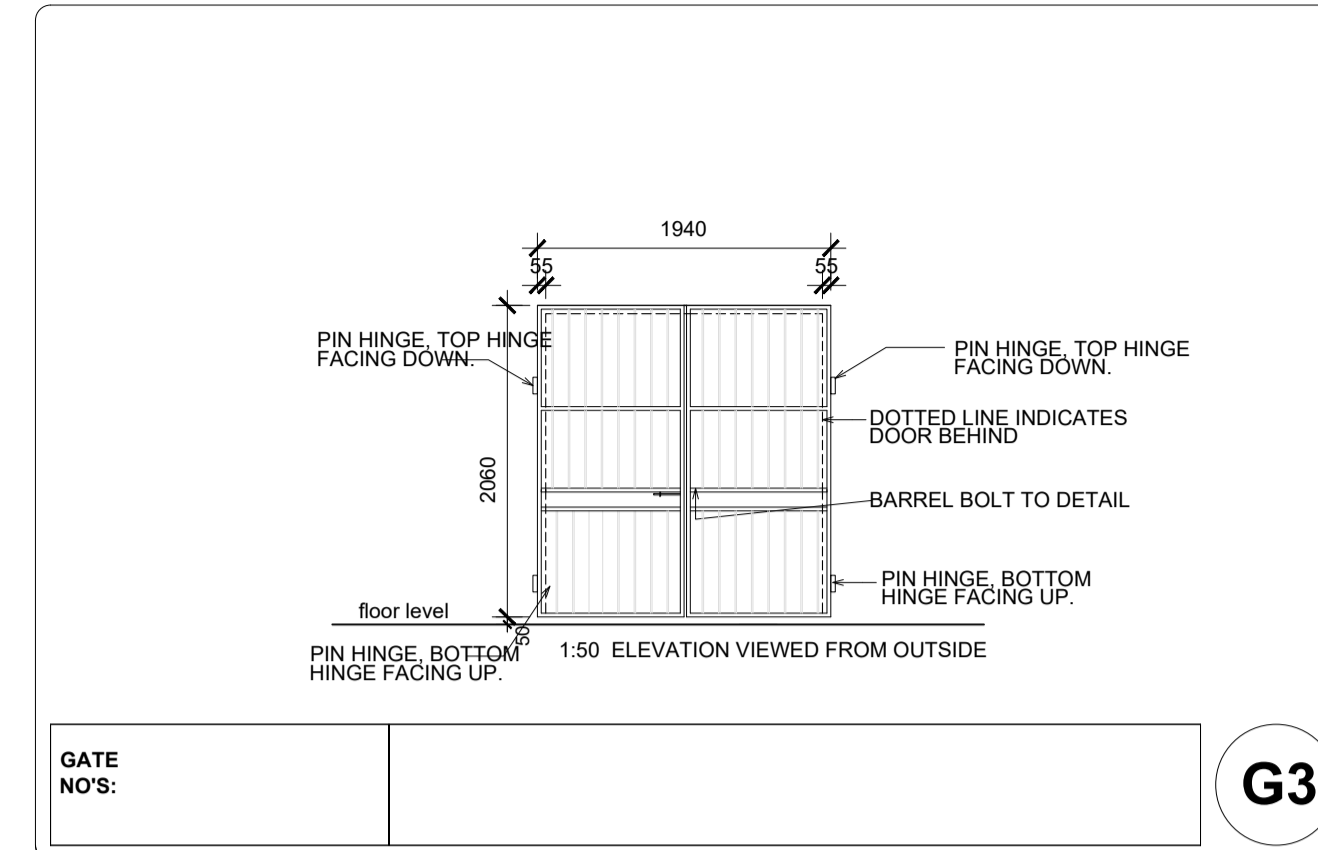

GATE NO'S:		G3
NO. REQD.	2	
DESCRIP.	DOUBLE GRILLE GATE CONSTRUCTED FROM 25 X 25 X 2.5MM SQUARE SECTION TUBING WITH 10MM SOLID M/S RODS AT APPROX. 120MM CENTRES. PROVIDE 4MMØ WEEP HOLES TO BOTTOM OF ALL TUBING.	
IRONM.	UNION PADLOCK CODE 3122-51 HEAVY DUTY PADLOCK WITH BRASS BODY S/S SHACKLE 5 PIN TUMBLER. SOLID 100MM BARREL BOLT TO TAKE PADLOCK.	
FINISH	PRE-PAINTED POWDER COATED SATIN BLACK ON TOP OF A UNIVERSAL RED OXIDE METAL PRIMER SOLVENT-BASED ANTI-CORROSIVE METAL PRIMER	
REMARKS	ALL DIMENSIONS TO BE CHECKED ON SITE PRIOR TO MANUFACTURE. PIN HINGES TO BE BOLTED TO FACE BRICK WALL.	

OPD GATE 3
SCALE 1-50

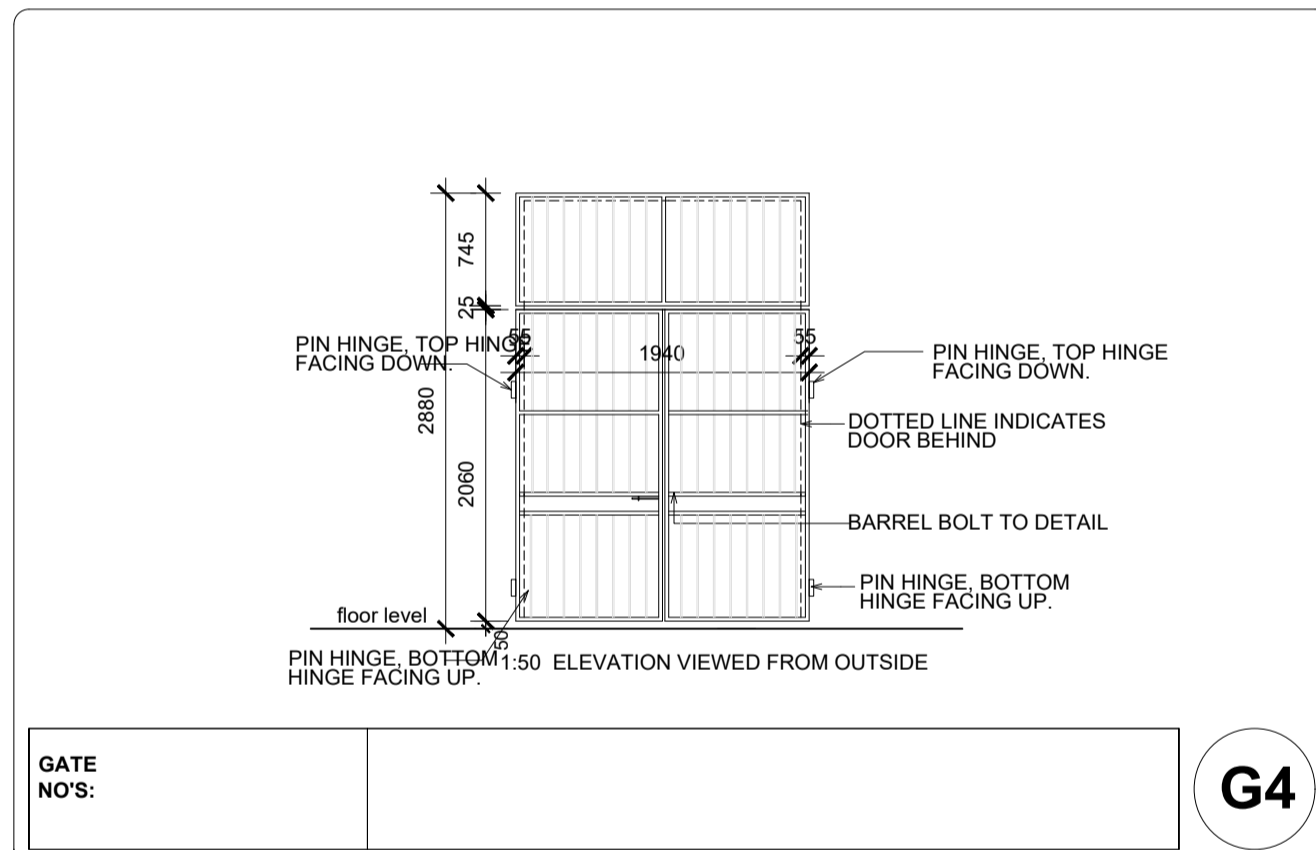

GATE NO'S:		G4
NO. REQD.	1	
DESCRIP.	DOUBLE GRILLE GATE CONSTRUCTED FROM 25 X 25 X 2.5MM SQUARE SECTION TUBING WITH 10MM SOLID M/S RODS AT APPROX. 120MM CENTRES. PROVIDE 4MMØ WEEP HOLES TO BOTTOM OF ALL TUBING.	
IRONM.	UNION PADLOCK CODE 3122-51 HEAVY DUTY PADLOCK WITH BRASS BODY S/S SHACKLE 5 PIN TUMBLER. SOLID 100MM BARREL BOLT TO TAKE PADLOCK.	
FINISH	PRE-PAINTED POWDER COATED SATIN BLACK ON TOP OF A UNIVERSAL RED OXIDE METAL PRIMER SOLVENT-BASED ANTI-CORROSIVE METAL PRIMER	
REMARKS	ALL DIMENSIONS TO BE CHECKED ON SITE PRIOR TO MANUFACTURE. PIN HINGES TO BE BOLTED TO FACE BRICK WALL.	

OPD GATE 4
SCALE 1-50

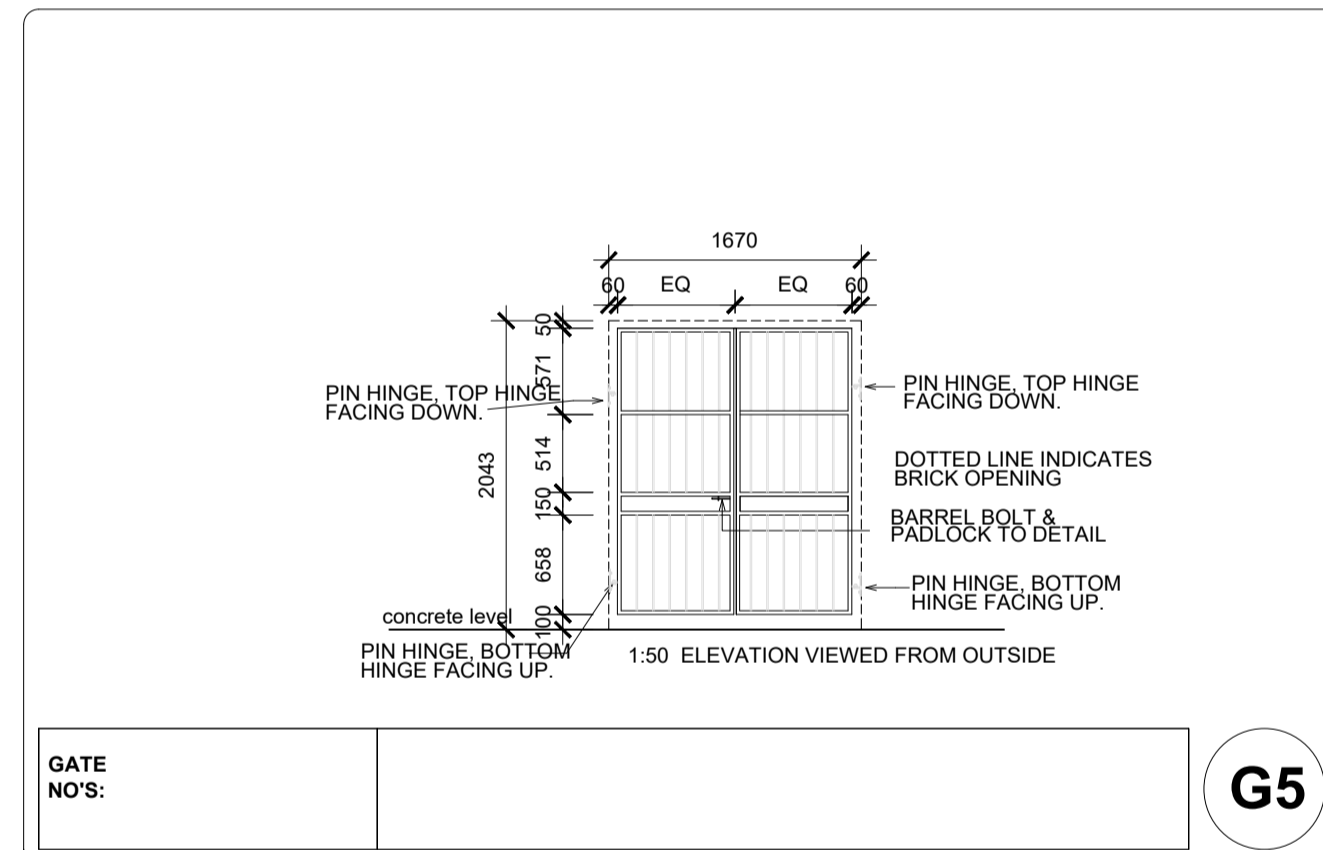

GATE NO'S:		G5
NO. REQD.	1	
DESCRIP.	DOUBLE GRILLE GATE CONSTRUCTED FROM 25 X 25 X 2.5MM SQUARE SECTION TUBING WITH 10MM SOLID M/S RODS AT APPROX. 120MM CENTRES. PROVIDE 4MMØ WEEP HOLES TO BOTTOM OF ALL TUBING.	
IRONM.	UNION PADLOCK CODE 3122-51 HEAVY DUTY PADLOCK WITH BRASS BODY S/S SHACKLE 5 PIN TUMBLER. SOLID 100MM BARREL BOLT TO TAKE PADLOCK.	
FINISH	PRE-PAINTED POWDER COATED SATIN BLACK ON TOP OF A UNIVERSAL RED OXIDE METAL PRIMER SOLVENT-BASED ANTI-CORROSIVE METAL PRIMER	
REMARKS	ALL DIMENSIONS TO BE CHECKED ON SITE PRIOR TO MANUFACTURE. PIN HINGES TO BE BOLTED TO FACE BRICK WALL.	

OPD GATE 5
SCALE 1-50

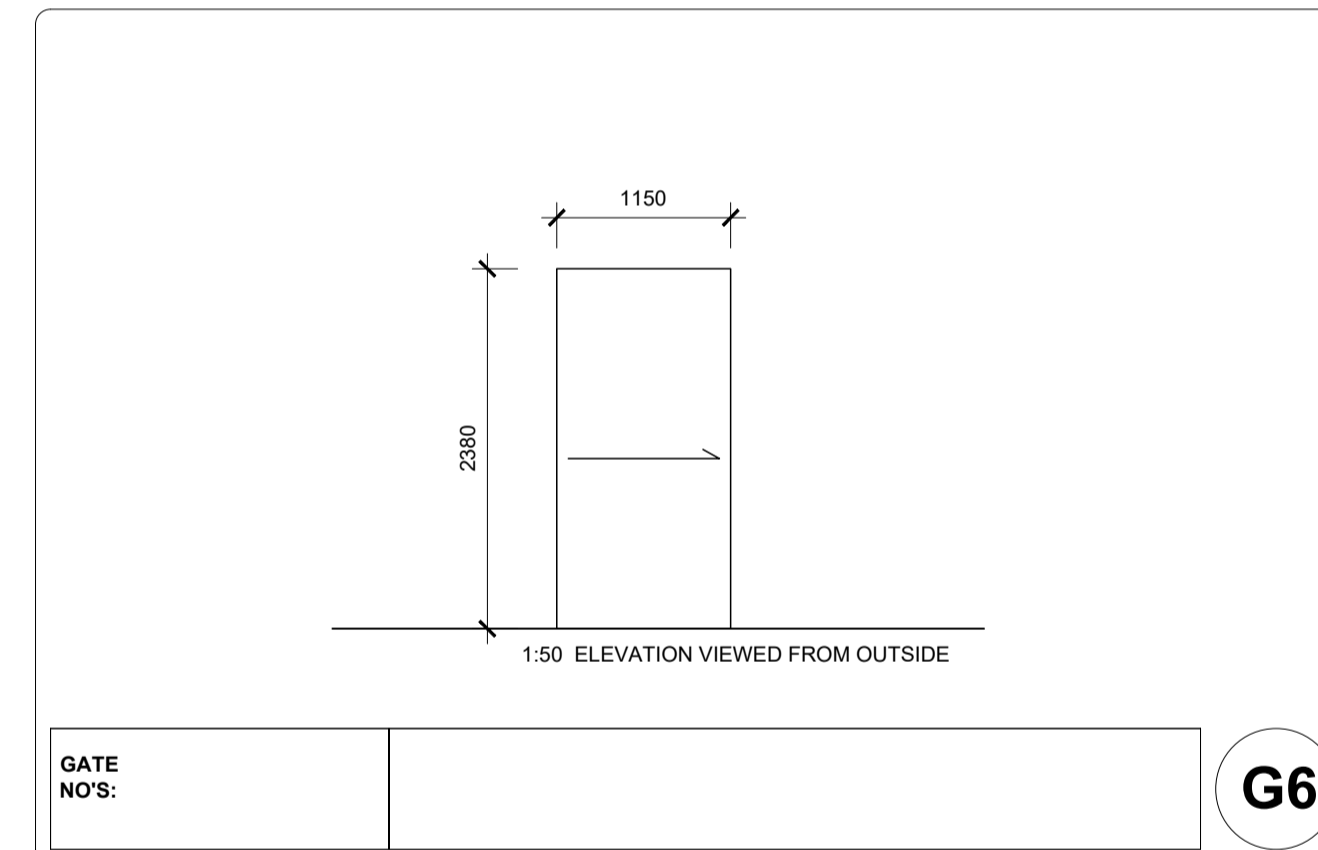

GATE NO'S:		G6
NO. REQD.	1	
DESCRIP.	SLIDING TRELLIDOR GATE WITH FLOOR AND CEILING RAILS.	
IRONM.	DEAD LOCK FACTORY FITTED.	
FINISH	FACTORY POWDER COATED WHITE	
REMARKS	ALL DIMENSIONS TO BE CHECKED ON SITE PRIOR TO MANUFACTURE. SLAM LOCK FUNCTION IS NOT TO BE INSTALLED DOOR TO BE FITTED IN THE PREFABRICATED UNIT 500mm FROM THE ENTRANCE DOOR DOOR TO BE RIVETED IN.	

EYE CLINIC ENTRANCE GATE 6
SCALE 1-50

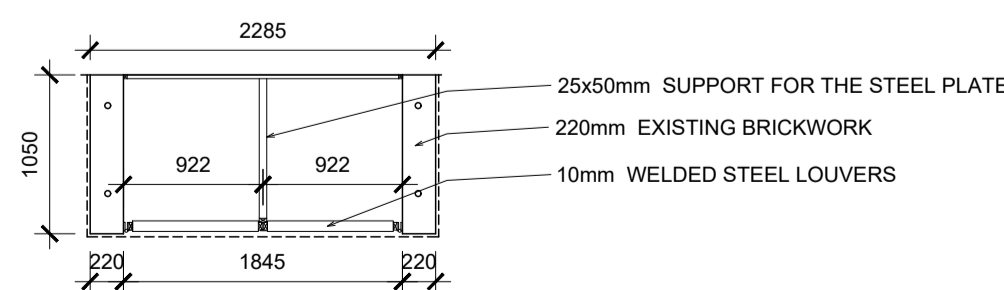
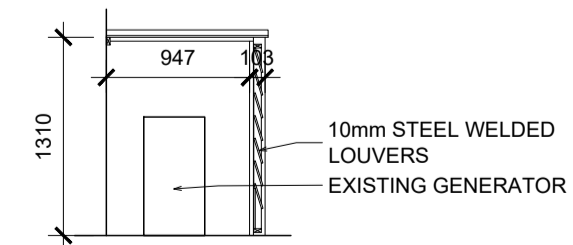
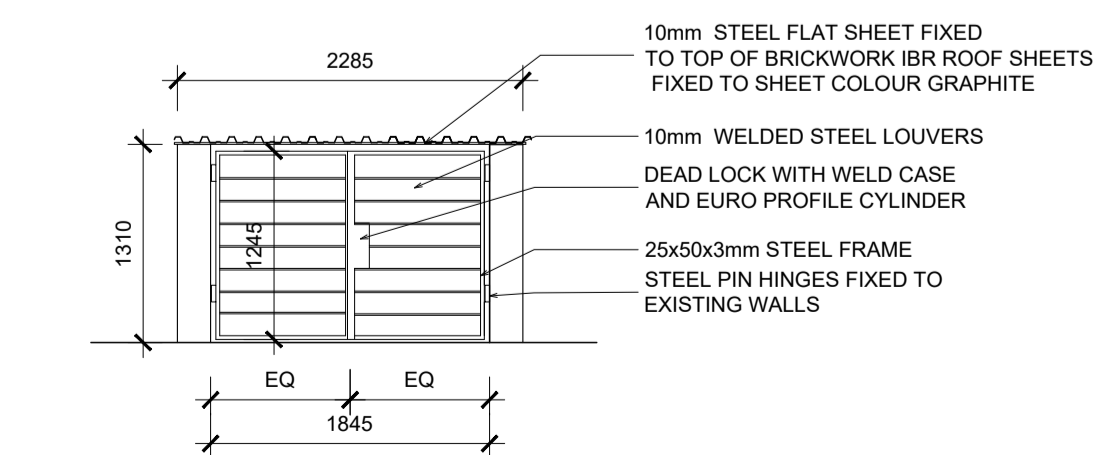

DENTAL GENERATOR ELEVATION
SCALE 1-50

DENTAL GENERATOR SECTION
SCALE 1-50

DENTAL GENERATOR PLAN
SCALE 1-50

NOTES

ALL DIMENSIONS AND LEVELS ARE TO BE VERIFIED ON SITE PRIOR TO COMMENCING, SETTING OUT, WORKSHOP DRAWINGS OR CONSTRUCTION
FIGURED DIMENSIONS ONLY TO BE USED, DRAWINGS ARE NOT TO BE SCALED
DISCREPANCIES, ERRORS AND OMISSIONS ARE TO BE BROUGHT TO THE ARCHITECTS ATTENTION IMMEDIATELY THEY BECOME EVIDENT
SHOP DRAWINGS TO BE SUBMITTED FOR APPROVAL PRIOR TO MANUFACTURE OR INSTALLATION
COPYRIGHT AND RIGHT OF REPRODUCTION OF THIS DRAWING OR ANY PORTION THEREOF IS RESERVED BY THE ARCHITECTS



Rev	Date	Revision

Project
ECDOH PMU-2
Butterworth Hospital

Title
OPD BUILDING GROUND GATES

Scale	Date	Drawn	Checked
VARIOUS	2024-07-15	RSC	WAM

DRAWING No
240028-PRF-17-205

